

OVERALL DIMENSIONS

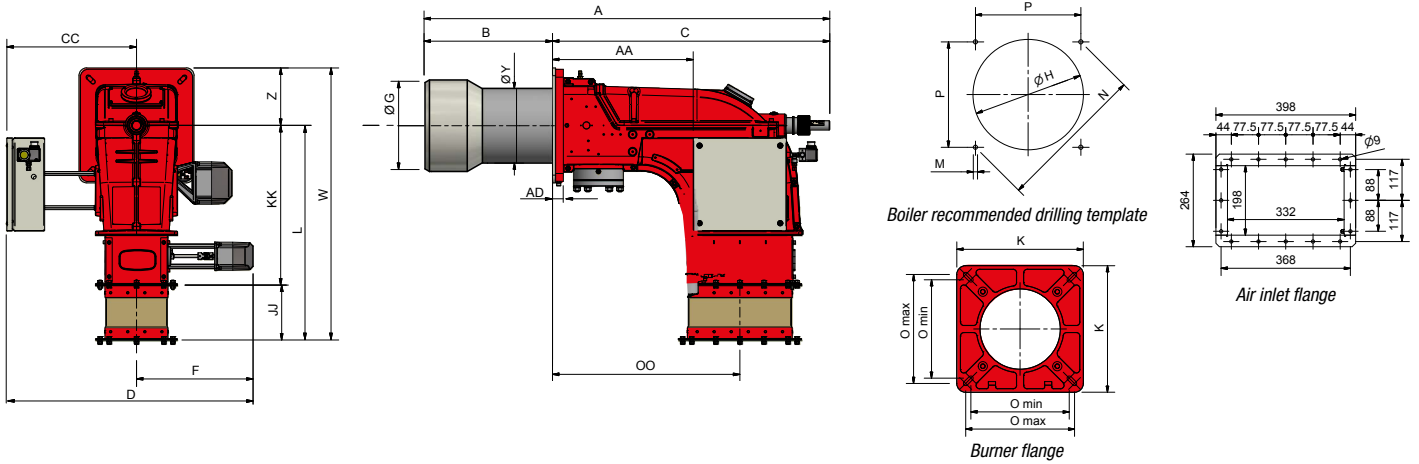

Type	Overall dimensions (mm)																											
	AS	AL	AA	AD	BS	BL	C	CC	D	E	F	G	H	J	JJ	K	KK	L	M	N	O		OO	P	W	Y	Z	
																					min.	max.						
TG90	1406	1556	454	28	340	490	1066	305	1349	859	490	234	264	449	175	360	510	685	M12	424	280	310	610	300	870	198	185	
TG91	1366	1539	454	28	300	473	1066	305	1349	859	490	238	268	449	175	360	510	685	M12	424	280	310	610	300	870	228	185	
TG92	1360	1533	454	28	294	467	1066	305	1349	859	490	266	296	449	175	360	510	685	M12	424	280	310	610	300	870	228	185	

Dimensions CC - D refer to burners with maximum overall dimensions of hot air and mechanical version models. In standard and electronic versions these dimensions may be smaller.