

OVERALL DIMENSIONS

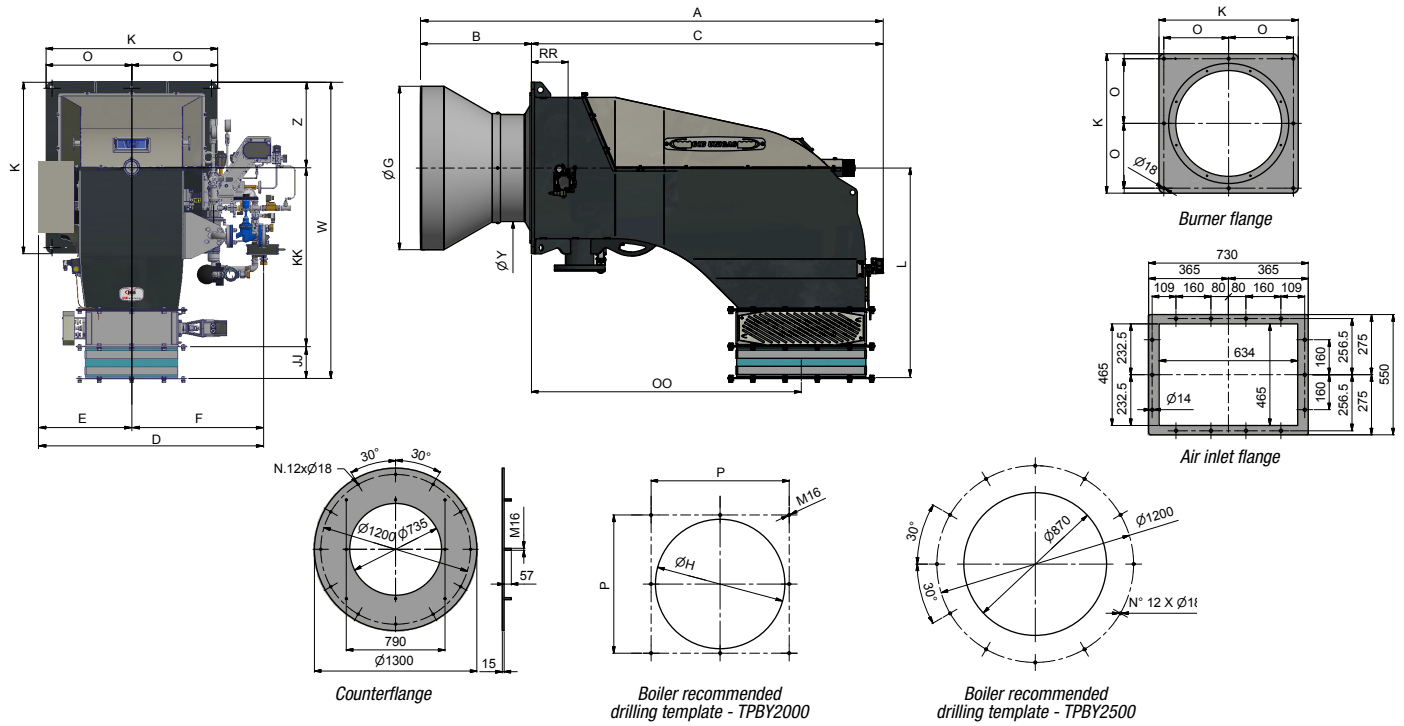

Type	Overall dimensions (mm)																		
	A	B	C	D	E	F	G	H	JJ	K	KK	L	M	O	OO	RR	W	Y	Z
TPBY2000	2293	550	1743	1480	730	750	700	760	160	850	883	1043	M16	395	1337	215	1468	530	425
TPBY2500	2293	550	1743	1480	730	750	810	870	160	850	883	1043	M16	395	1337	215	1468	530	425