

OVERALL DIMENSIONS (HTLX... - HTLX...FGR)

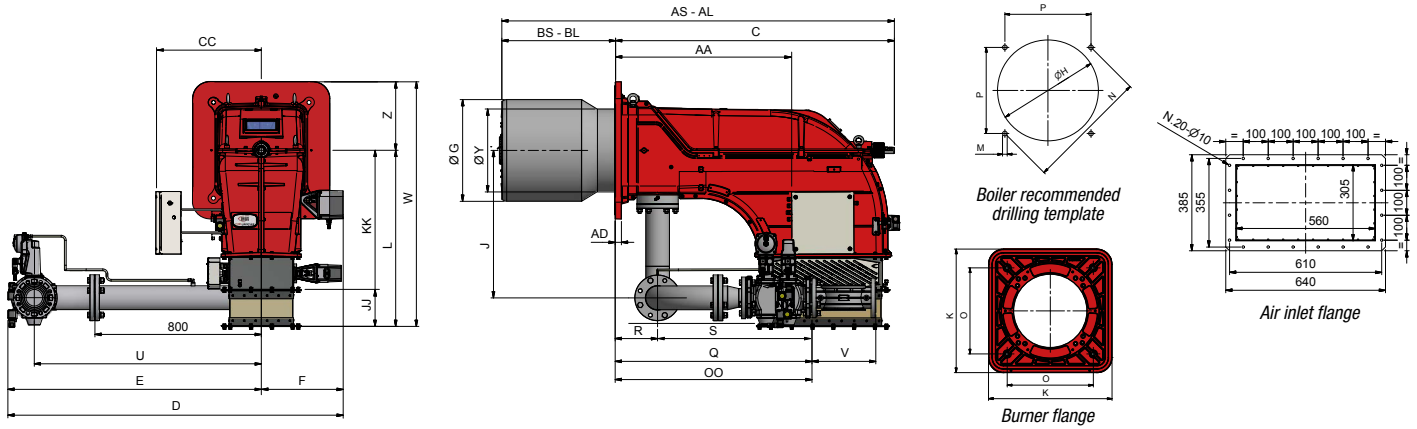

Type	DN	Overall dimensions (mm)																														
		AS	AL	AA	AD	BS	BL	C	CC	D	E	F	G	H	J	JJ	K	KK	L	M	N	O	OO	P	Q	R	S	U	V	W	Y	Z
HTLX1030R	80	1986	2086	848	30	445	545	1541	540	1816	1219	520	446	500	709	175	660	672	845	M16	651	460	1000	460	937	204	733	1092	310	1175	448	329
HTLX1030R	100	1986	2086	848	30	445	545	1541	540	1816	1219	520	446	500	709	175	660	672	845	M16	651	460	1000	460	937	204	733	1092	350	1175	448	329
HTLX1030R	125	1986	2086	848	30	445	545	1541	540	1816	1219	520	446	500	709	175	660	672	845	M16	651	460	1000	460	937	204	733	1092	478	1175	448	329
HTLX1030.1	80	1986	2086	848	30	445	545	1541	540	1816	1219	520	489	541	709	175	660	672	845	M16	651	460	1000	460	937	204	733	1092	310	1175	399	329
HTLX1030.1	100	1986	2086	848	30	445	545	1541	540	1816	1219	520	489	541	709	175	660	672	845	M16	651	460	1000	460	937	204	733	1092	350	1175	399	329
HTLX1030.1	125	1986	2086	848	30	445	545	1541	540	1816	1219	520	489	541	709	175	660	672	845	M16	651	460	1000	460	937	204	733	1092	478	1175	399	329

Dimensions CC - U - E - D refer to burners with maximum overall dimensions of hot air and mechanical version models. In standard and electronic versions these dimensions may be smaller.